

FLUID POWER SYMBOL

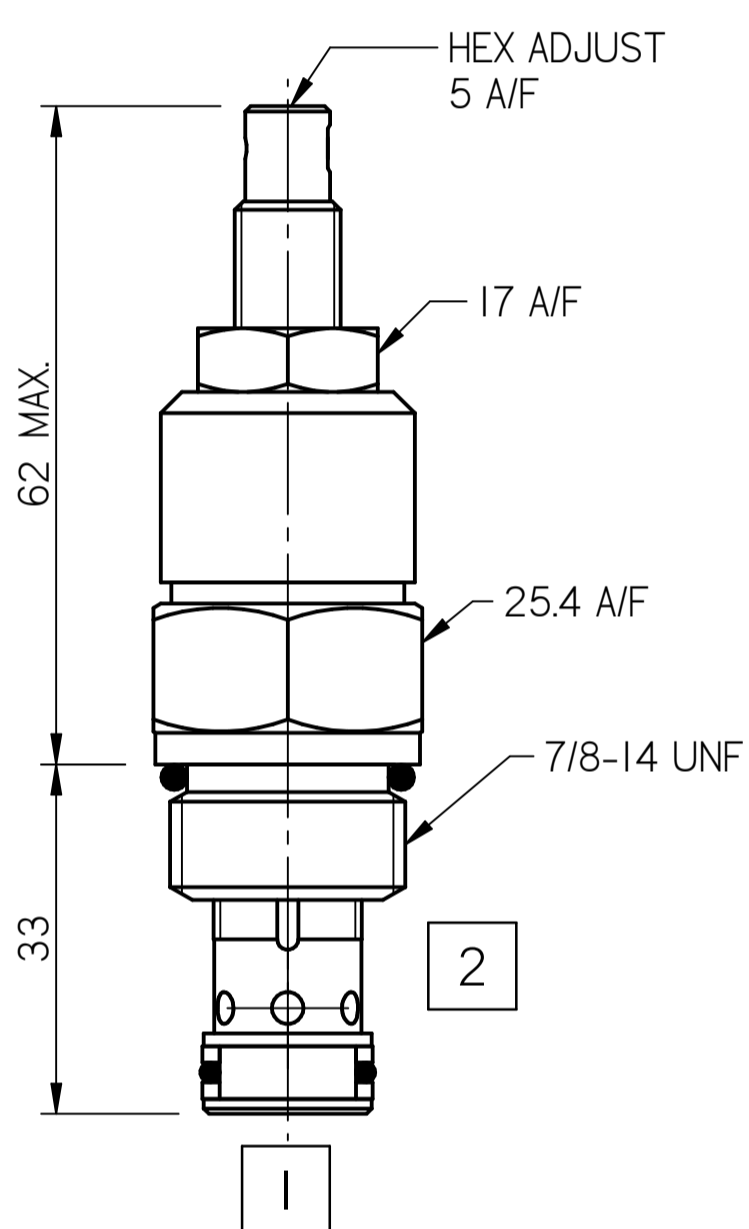
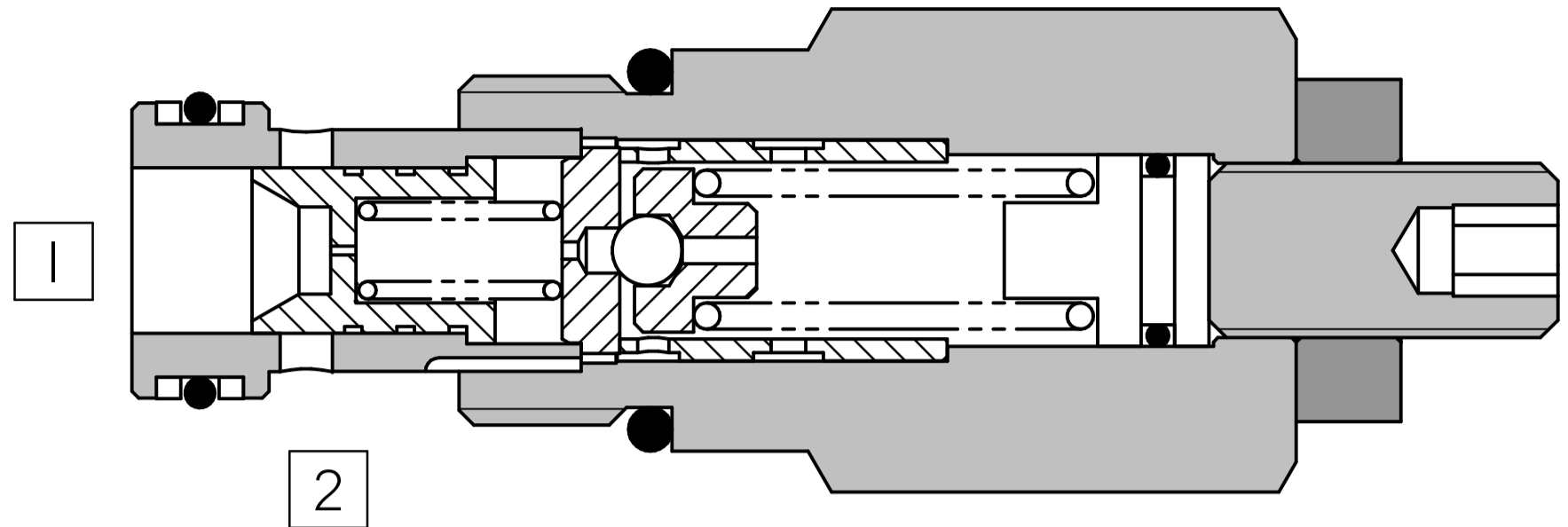
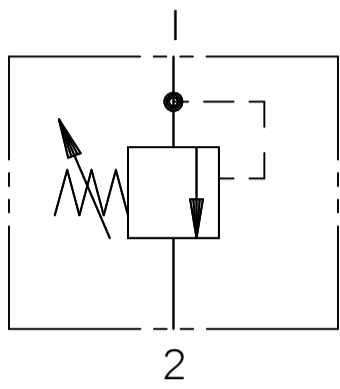

Application

Pressure Relief valves are used to limit the pressure in the system as set on the valve. Pilot Operated Relief Valves are applicable more in systems where pressure regulation is needed over pressure safety. The barrel-piston assembly of the valve implies that the valve is not a zero leak valve and cannot be used for load holding applications. The valve is ideal for continuous duty providing accurate pressure control with constant or varying flows.

Operation

When the inlet pressure at 1 (Pressure Port) exceeds the setting of the valve, the ball unseats causing the pilot

section to open. This results in a small flow across the orifice in the main spool. The subsequent pressure drop moves the secondary spool against a light spring opening a ring of radial holes in the sleeve and allowing relief flow to 2 (Tank Port)

Features

Very low pressure rise for any increase in flow giving accurate pressure control. Smooth operation due to presence of a balanced piston. Hardened working parts ensure a long, reliable, trouble-free life. Cartridge construction gives maximum flexibility in mounting

Specifications

Figures based on: Oil Temp = 40°C Viscosity = 40 cSt

Rated Flow	65 lpm
Max Setting	350 bar
Cartridge Material	Working parts : Hardened, ground steel External surfaces : Zinc plated
Weight (Cartridge only)	ARI10: 0.195 kg
Cavity Number	SAE0-2 (Refer Cavities Section)
Manifold Material	Aluminium (upto 250 bar) Add Suffix '729' for SG Iron (350 bar)
Torque into Cavity	45 Nm
Mounting	Line
Seal Kit Number	SKAR10 (Nitrile) SKAR65 V (Viton®)
Filtration Level	BS5540/4 Class 18/13 (25µ nominal)
Operating Temp	-20°C to +90°C (Standard Seals)
Leakage	Less than 35 millilitres/min
Viscosity Range	5 to 500 cSt

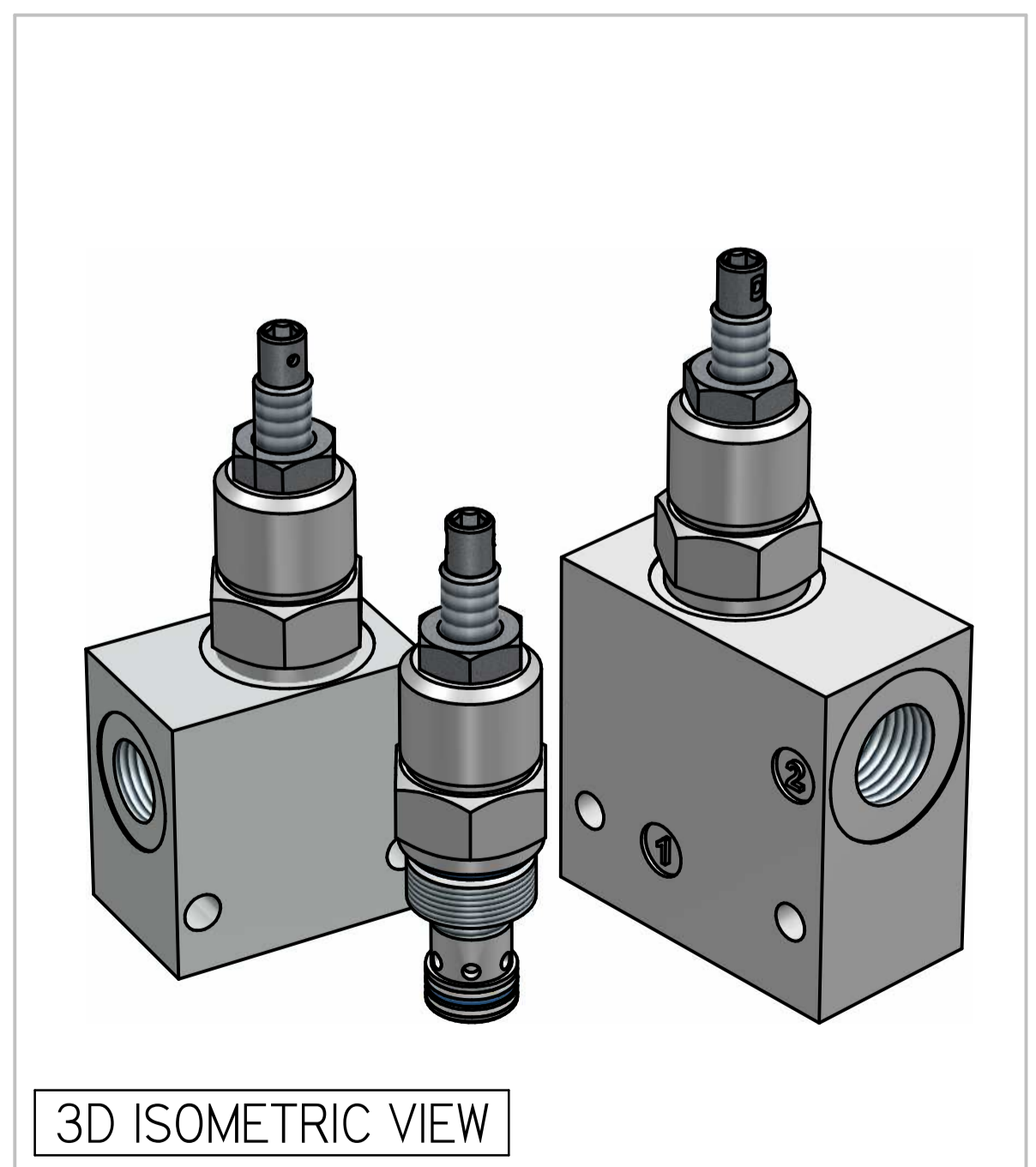

Where measurements are critical request certified drawings. We reserve the right to change specifications without notice.

TO ORDER

ARIO P 4W 35 N

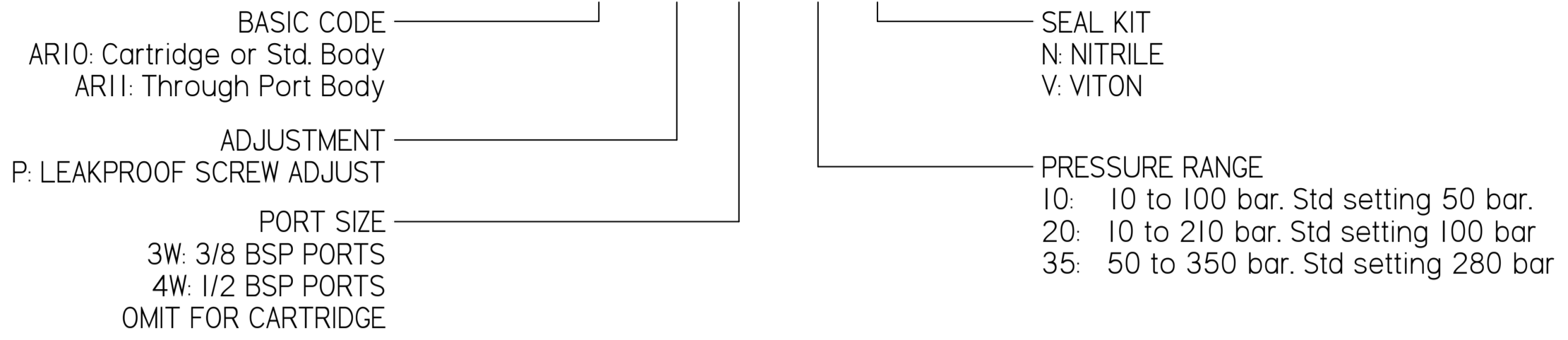

PRESSURE CHARACTERISTICS

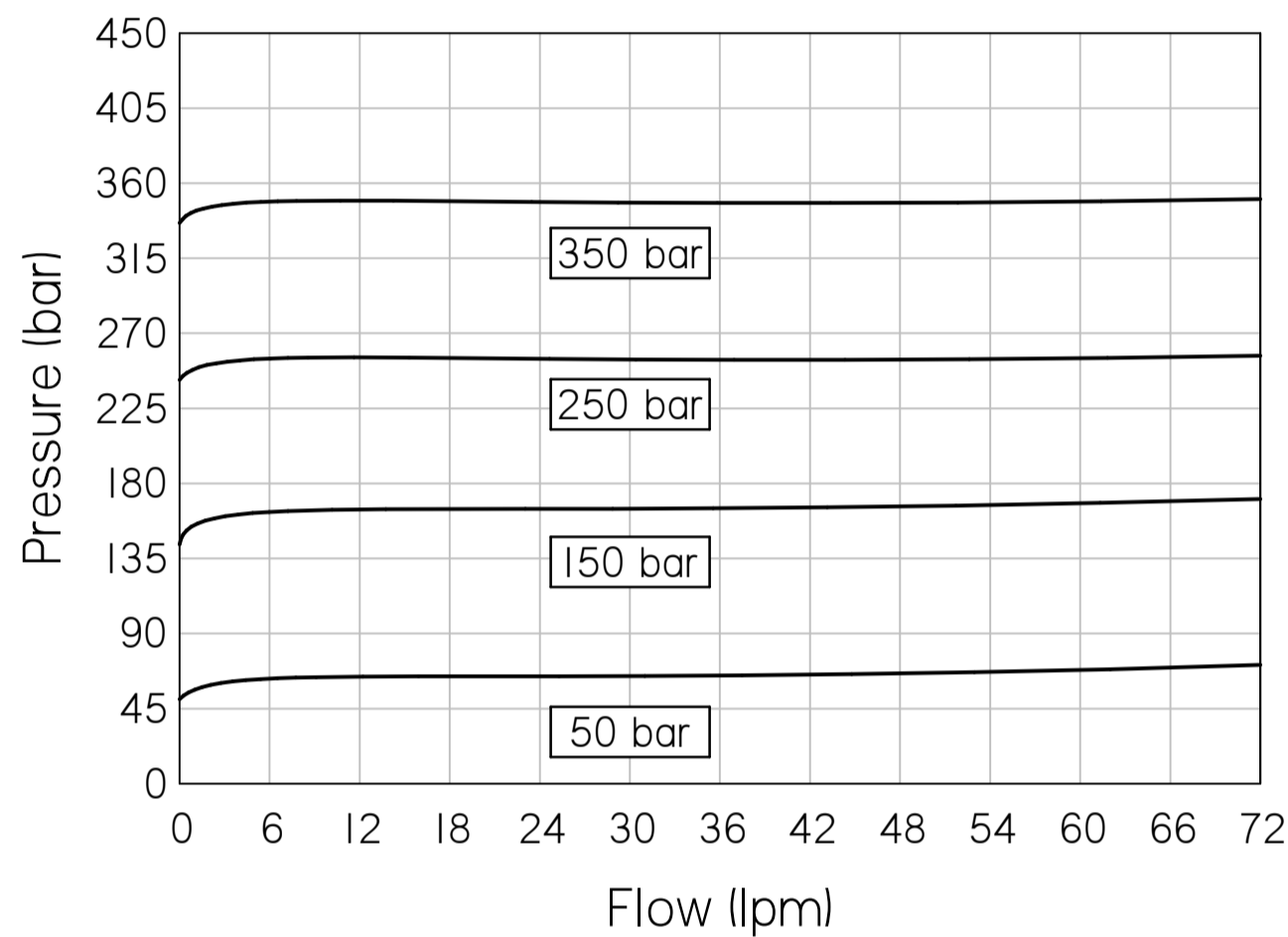

COMPLETE VALVE 3/8" 1/2" BSP PORTS

BASIC CODE: ARI0 3W / ARI0 4W

ONLY Body Part Numbers (BSP)

Aluminium		SG Iron	
3/8"	Z10221	3/8"	Z10221S
1/2"	Z10212	1/2"	Z10212S

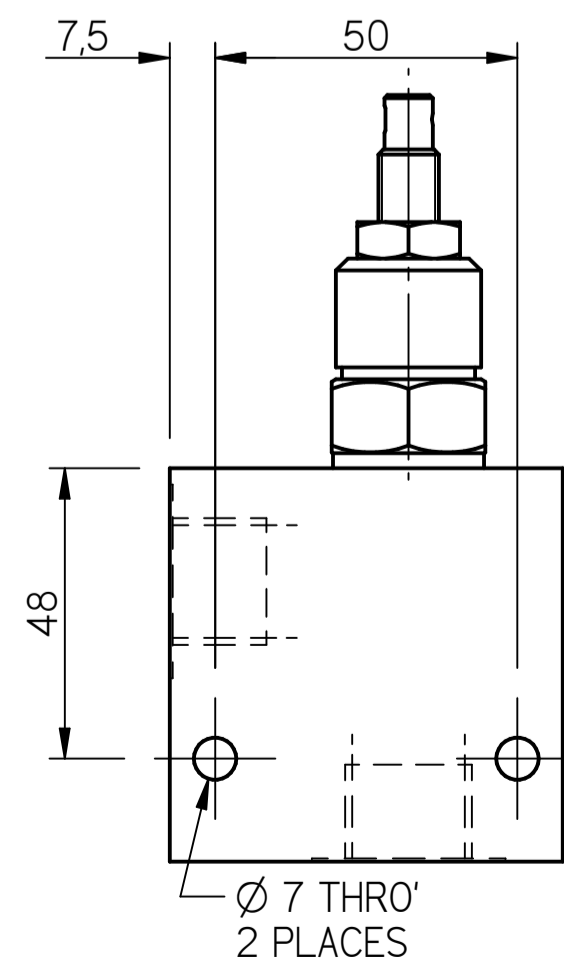
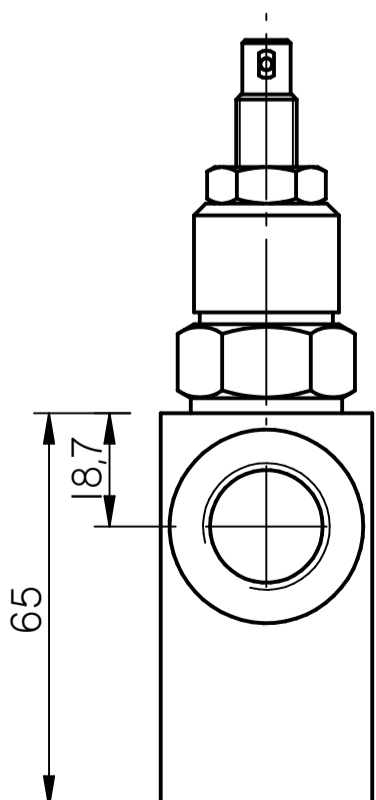
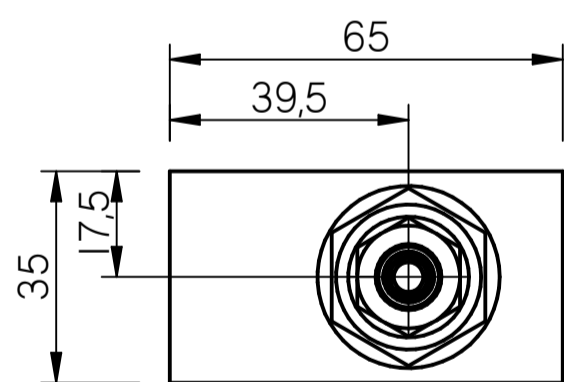
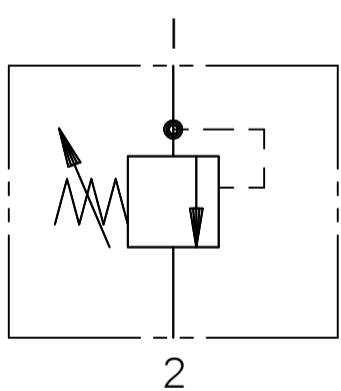

COMPLETE VALVE 1/2" BSP PORTS

BASIC CODE: ARII 4W

ONLY Body Part Numbers (BSP)

Aluminium		SG Iron	
1/2"	Z10248	1/2"	Z10248S

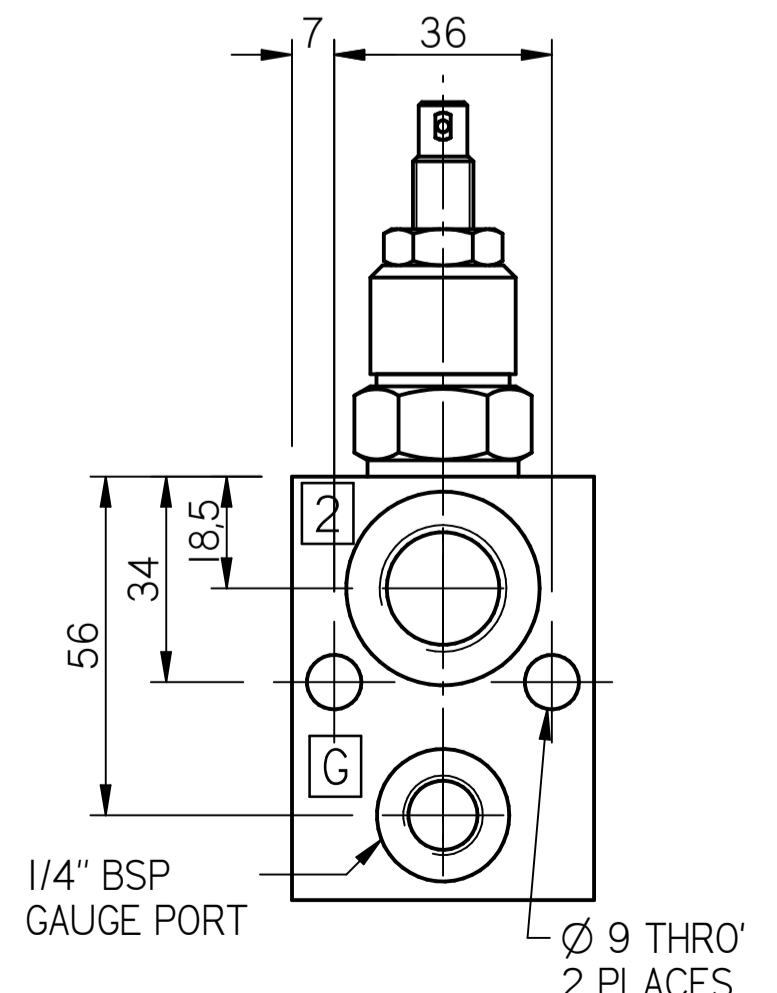
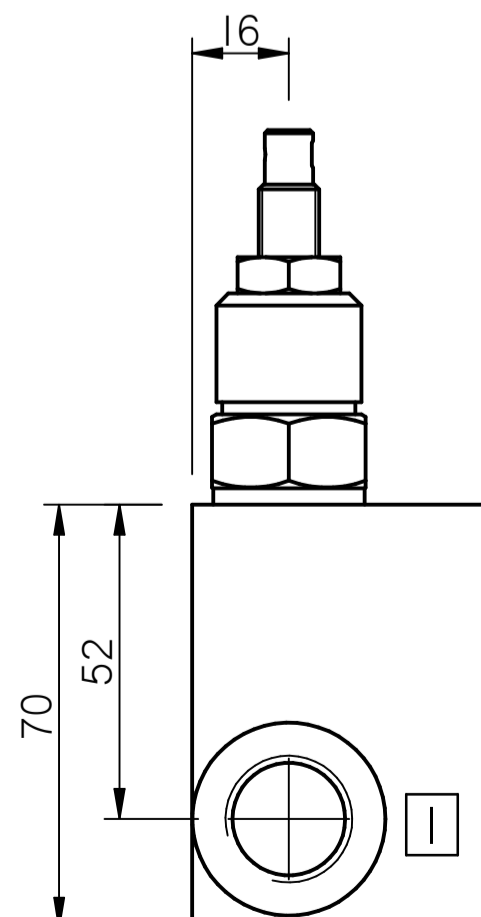
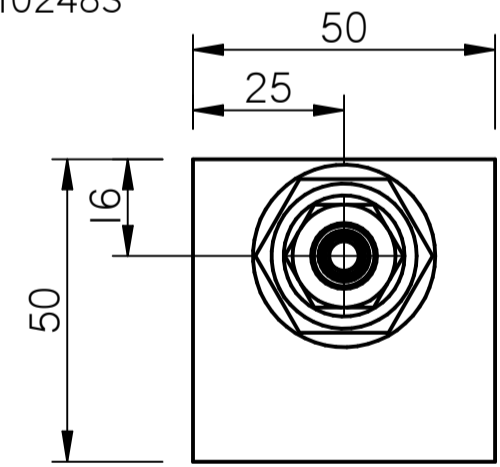
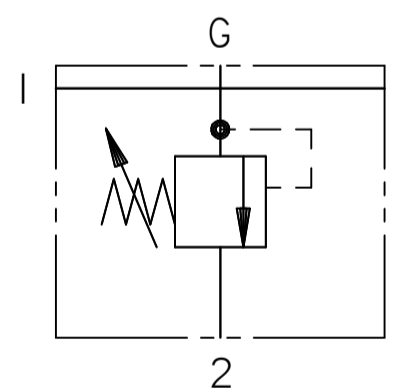

Where measurements are critical request certified drawings. We reserve the right to change specifications without notice.