

FLUID POWER SYMBOL

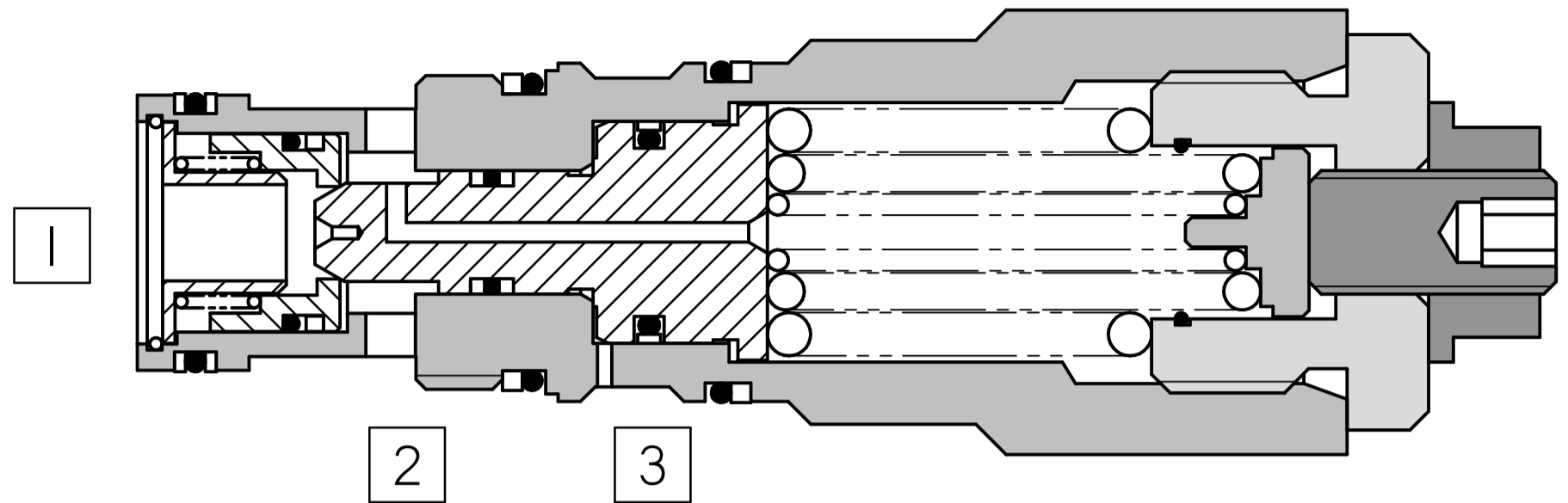

4

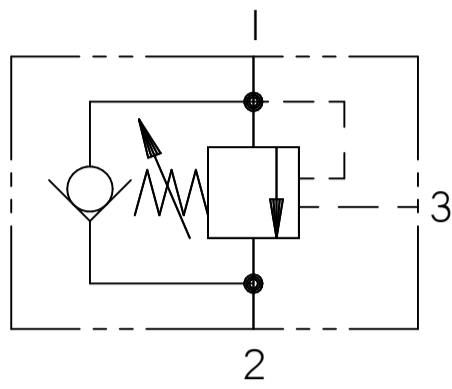
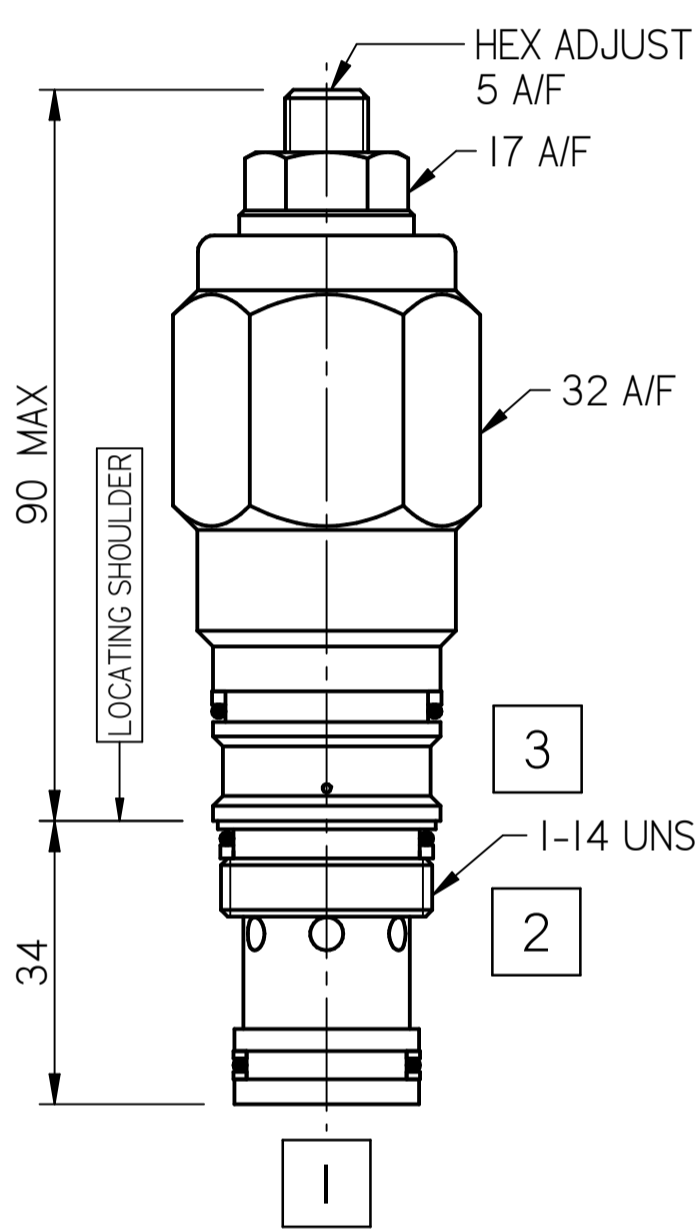

Application

Overcentre valves give static and dynamic control of loads by regulating flow into and out of hydraulic actuators. The Overcentre valve will stop the load from running away in the event of a hose burst. If open center directional control valves are used, they will allow the thermal expansion relief of the hydraulic fluid. These valves provide excellent hose burst protection.

Operation

The check section allows free flow into the actuator (from 2 to 1) then holds and locks the load against movement (from 1 to 2). The pilot pressure in the pilot port (3) will give a controlled movement to piston when the pressure is applied. The

pressure required to open the valve and allow movement depends on the pilot ratio of the valve. The pressure required to open the valve and start actuator movement can be calculated as follows:

$$\text{Pilot Pressure} = \frac{\text{Relief Setting} - \text{Load Pressure}}{\text{Pilot Ratio}}$$

Pilot Ratio

4:1 Best suited for applications where the load varies and machine structure can induce instability. Other ratios can be made available upon request.

Specifications

Figures based on: Oil Temp = 40°C Viscosity = 40 cSt

Max Flow	120 lpm
Max Setting	Load Induced Pressure : 270 bar Relief Setting : 350 bar
Cartridge Material	Working parts : Hardened, ground steel External surfaces : Zinc plated
Weight (Cartridge only)	OSC95: 0.220 kg
Cavity Number	THSC2A (Refer Cavities Section)
Torque into Cavity	60 Nm
Mounting	Line
Seal Kit Number	SK0SC95 (Nitrile) SK0SC95 V (Viton®)
Filtration Level	BS5540/4 Class 18/13 (25µ nominal)
Operating Temp	-20°C to +90°C (Standard Seals)
Leakage	Less than 0.3 millilitres/min (5 dpm)
Viscosity Range	5 to 500 cSt

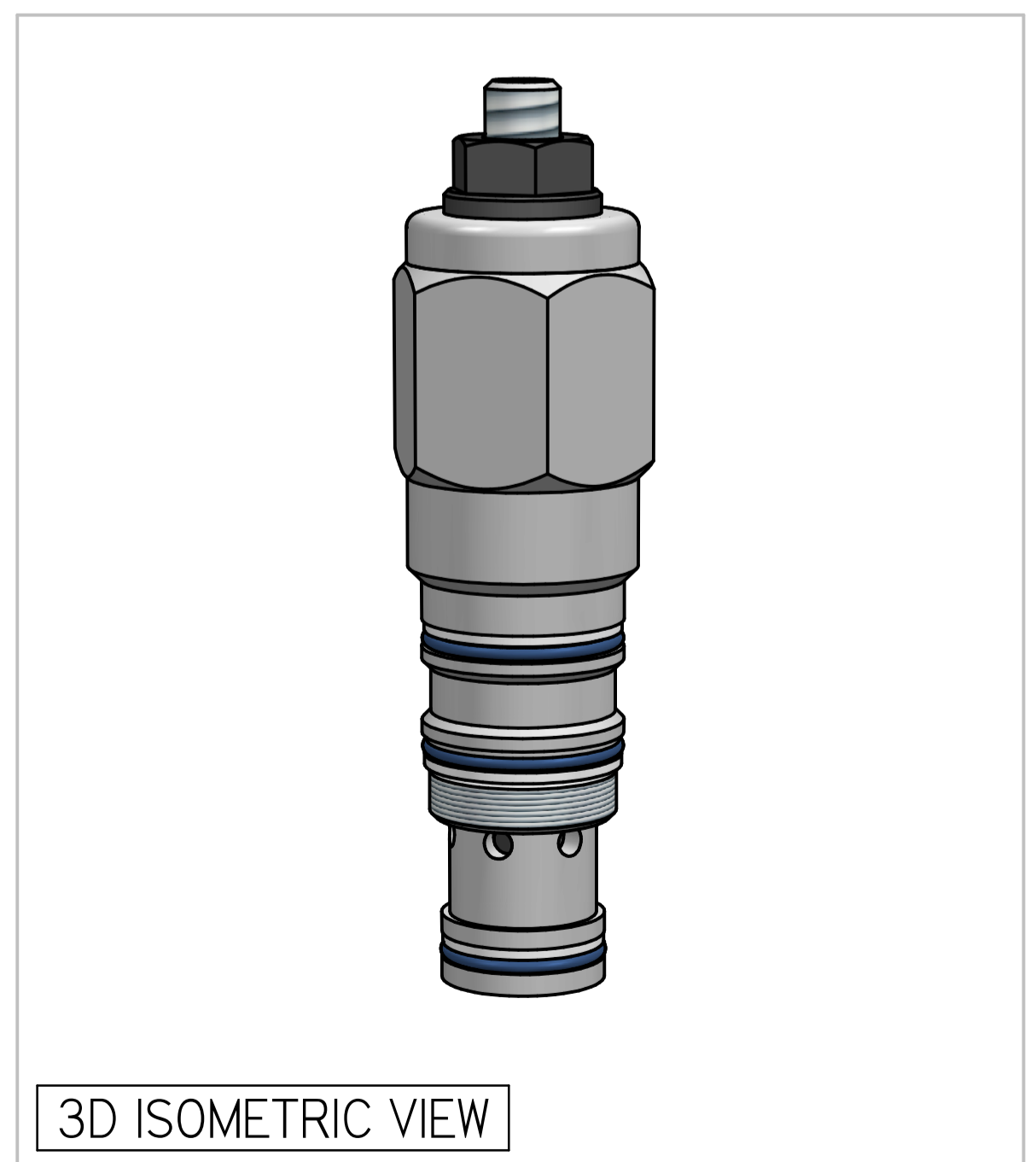

3D ISOMETRIC VIEW

Where measurements are critical request certified drawings. We reserve the right to change specifications without notice.

TO ORDER

OSC95 F 35 N 4

- BASIC CODE
- ADJUSTMENT
F: SCREW ADJUST
- PRESSURE RANGE
20: 70 to 225 bar. Std setting 100 bar
35: 70 to 350 bar. Std setting 210 bar
- AREA RATIO
4: RATIO OF 4:1
- SEAL KIT
N: NITRILE
V: VITON

PRESSURE CHARACTERISTICS

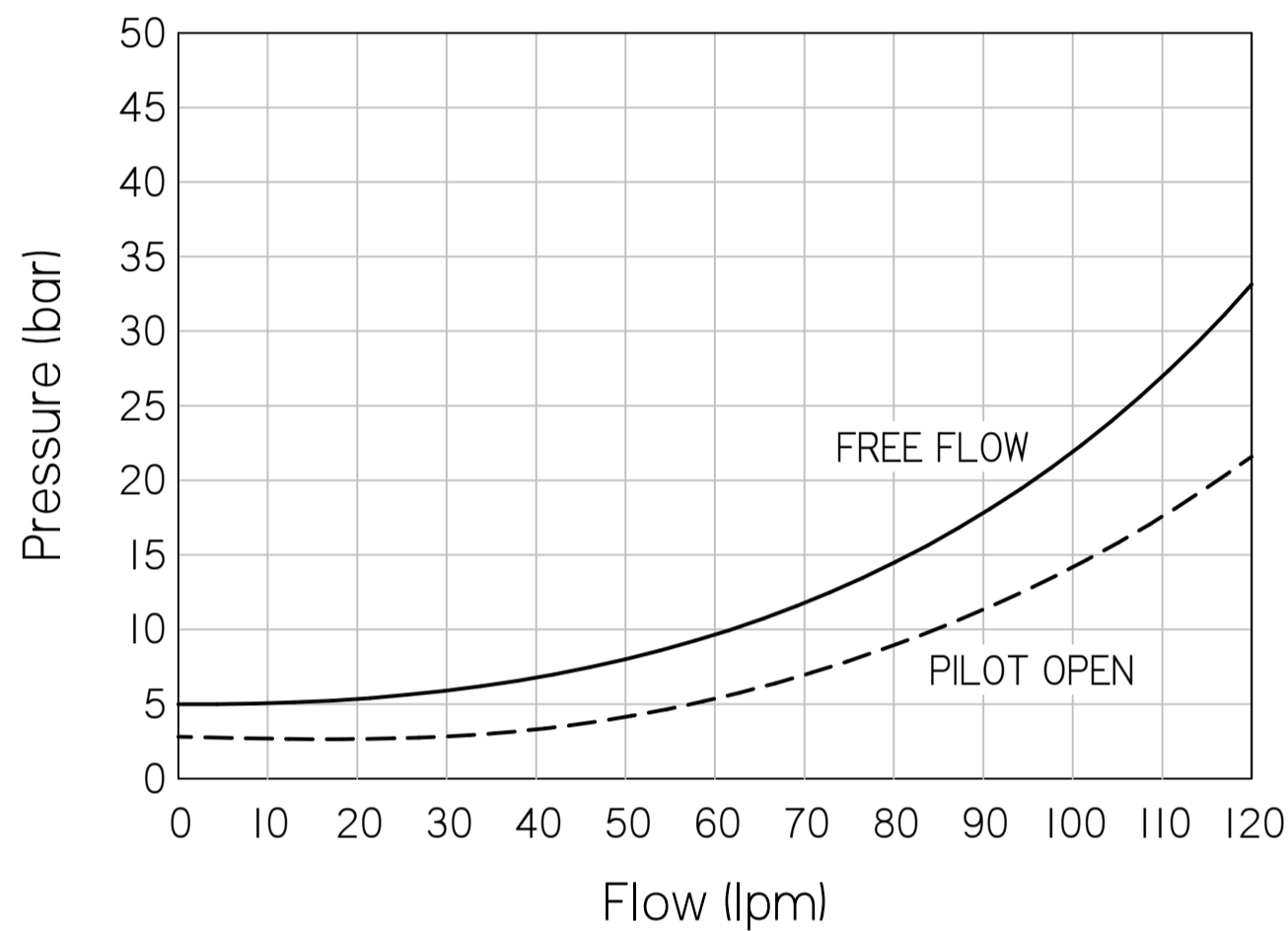

COMPLETE VALVE 1/2" BSP PORTS

BASIC CODE:

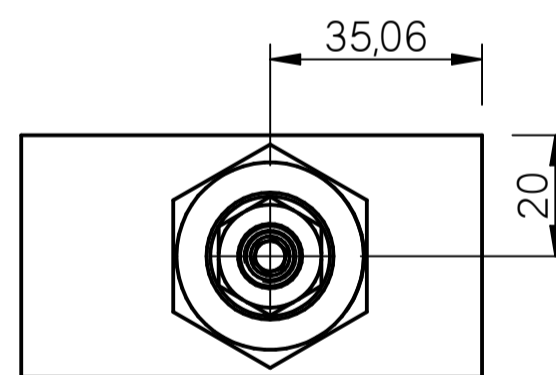
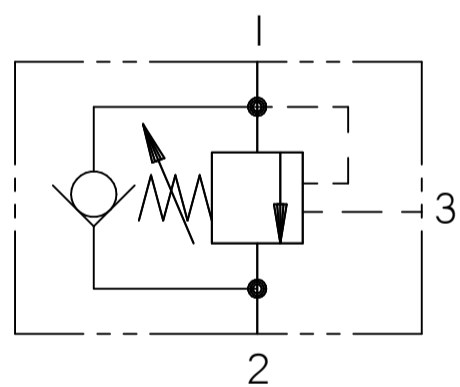

**SUGGESTED BODY
NOT IN CURRENT PRODUCT RANGE**

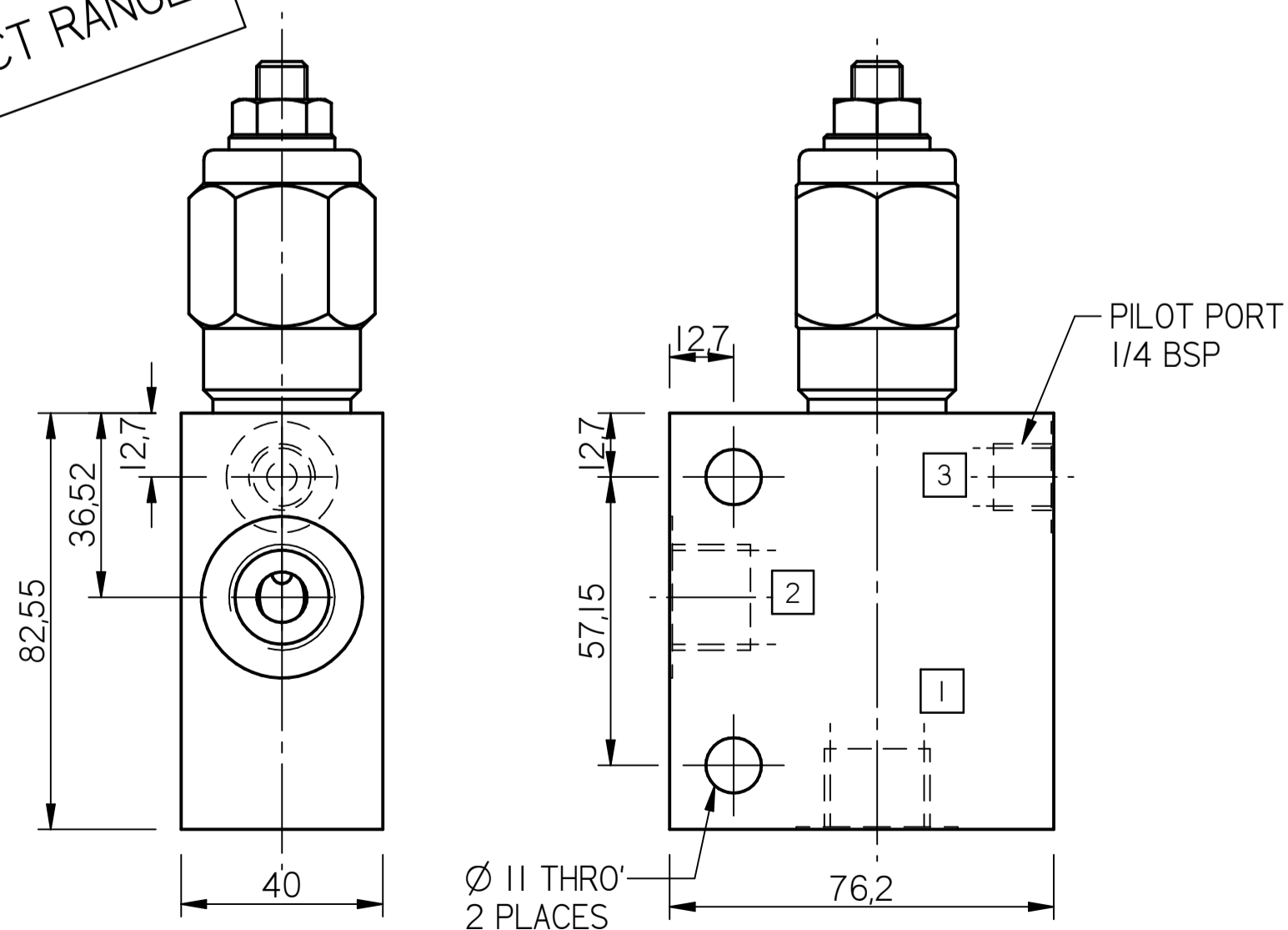

Where measurements are critical request certified drawings. We reserve the right to change specifications without notice.